

## PH6M user's guide

[www.renishaw.com](http://www.renishaw.com)

# PH6M user's guide

Document part number H-1000-5001-04-C



## PH6M user's guide

www.renishaw.com

# General information

© 2001 - 2020 Renishaw plc. All rights reserved.

This document may not be copied or reproduced in whole or in part, or transferred to any other media or language, by any means, without the prior written permission of Renishaw.

The publication of material within this document does not imply freedom from the patent rights of Renishaw plc.

## Disclaimer

RENISHAW HAS MADE CONSIDERABLE EFFORTS TO ENSURE THE CONTENT OF THIS DOCUMENT IS CORRECT AT THE DATE OF PUBLICATION BUT MAKES NO WARRANTIES OR REPRESENTATIONS REGARDING THE CONTENT. RENISHAW EXCLUDES LIABILITY, HOWSOEVER ARISING, FOR ANY INACCURACIES IN THIS DOCUMENT.

## Trademarks

**RENISHAW**, the probe symbol used in the RENISHAW logo and **REVO** are registered trademarks of Renishaw plc in the United Kingdom and other countries. **apply innovation** and names and designations of other Renishaw products and technologies are trademarks of Renishaw plc or its subsidiaries.

All brand names and product names used in this document are trade names, service marks, trademarks, or registered trademarks of their respective owners.

All trademarks and trade names are acknowledged.

## WEEE



The use of this symbol on Renishaw products and/or accompanying documentation indicates that the product should not be mixed with the general household waste upon disposal. It is the responsibility of the end user to dispose of this product at a designated collection point for waste electrical and electronic equipment (WEEE) to enable reuse or recycling. Correct disposal of this product will help save valuable resources and prevent potential negative effects on the environment. For more information, please contact your local waste disposal service or Renishaw distributor.

## Warranty

Renishaw plc warrants its equipment for a limited period (as set out in our Standard Terms and Conditions of Sale) provided that it is installed exactly as defined in associated Renishaw documentation.

Prior consent must be obtained from Renishaw if non-Renishaw equipment (e.g. interfaces and/or cabling) is to be used or substituted. Failure to comply with this will invalidate the Renishaw warranty.

Claims under warranty must be made from authorised service centres only, which may be advised by the supplier or distributor.

## PH6M user's guide

[www.renishaw.com](http://www.renishaw.com)

### Care of equipment

Renishaw probes and associated systems are precision tools used for obtaining precise measurements and must therefore be treated with care.

### Changes to Renishaw products

Renishaw reserves the right to improve, change or modify its hardware or software without incurring any obligations to make changes to Renishaw equipment previously sold.

### Packaging

To aid end user recycling and disposal the materials used in the different components of the packaging are stated here:

Packaging component	Material	94/62/EC code	94/62/EC number
Outer box	Corrugated fibreboard	PAP	20
Packing foam	Polyurethane	PU	7
Bag	Low density Polyethylene	LDPE	4

## PH6M user's guide

[www.renishaw.com](http://www.renishaw.com)

# Product compliance

## EU declaration of conformity

Contact Renishaw plc or visit [www.renishaw.com/EU](http://www.renishaw.com/EU) for the full EU declaration.

## EMC conformity

This equipment must be installed and used in accordance with this installation guide. This product is intended for industrial use only and should not be used in a residential area or connected to a low voltage power supply network which supplies buildings used for residential purposes.

## REACH regulation

Information required by Article 33(1) of Regulation (EC) No. 1907/2006 ("REACH") relating to products containing substances of very high concern (SVHCs) is available at:

[www.renishaw.com/REACH](http://www.renishaw.com/REACH)

## China RoHS

Contact Renishaw plc or visit [www.renishaw.com/ChinaRoHS](http://www.renishaw.com/ChinaRoHS) for the full China RoHS tabulation.



## PH6M user's guide

[www.renishaw.com](http://www.renishaw.com)

# Introduction

The PH6M is a shank mounted, fixed orientation, probe head incorporating the Renishaw autojoint probe connector.

The PH6M is compatible with the AM1 adjustment module to allow precise autojoint alignment with machine axes, enabling trouble-free autochange operation.

Probe reach may be extended using the PEM range of extension bars for multiwired probes or the PAA series for adapting to M8 connected probes.

Electrical connection is made via a 15-pin micro 'D' type connector. A range of mating cables is available with the remote end either terminated or unterminated according to installation requirements.

An integral LED indicates the status of touch-trigger probes.

# Installation and connection

The PH6M is fitted with an integral 15-pin micro 'D' socket. If required, this socket can be adapted by using a suitable cable to which a 5-pin DIN socket has been fitted.

Locking and unlocking the autojoint is performed either manually using the S10 joint key (supplied) or automatically using the Renishaw autochange system. This allows probes to be changed without the need to requalify.

PH6M user's guide

www.renishaw.com

# Dimensions

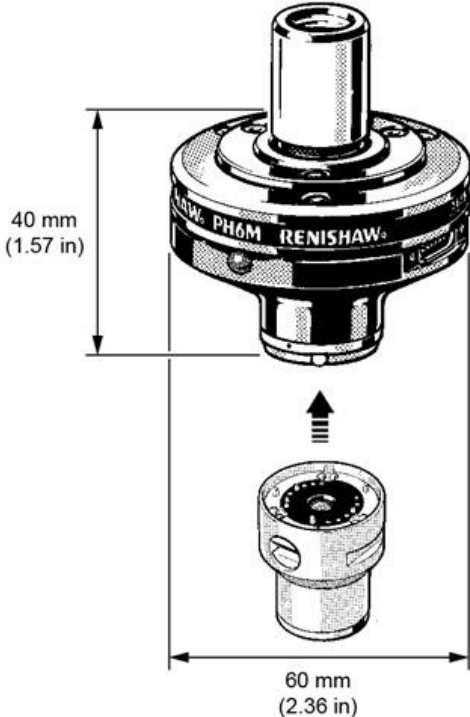

## PH6M user's guide

www.renishaw.com

# Operation

The autojoint is a highly repeatable coupling mechanism which will minimise the need for tip re-qualification after the exchange of probes or extension bars. The locking mechanism is operated by rotating an actuator contained in the mating half of the coupling, which is located on the probe or extension bar. The actuator has a drive slot which may be operated using an S10 joint key for manual probe or extension bar changing applications. Automatic probe or extension bar changing is possible using the Renishaw ACR1 or ACR3 autochange systems.

The status of the probe is indicated by the probe status LED. This is normally lit when the probe is ready for use and extinguishes as the probe triggers.

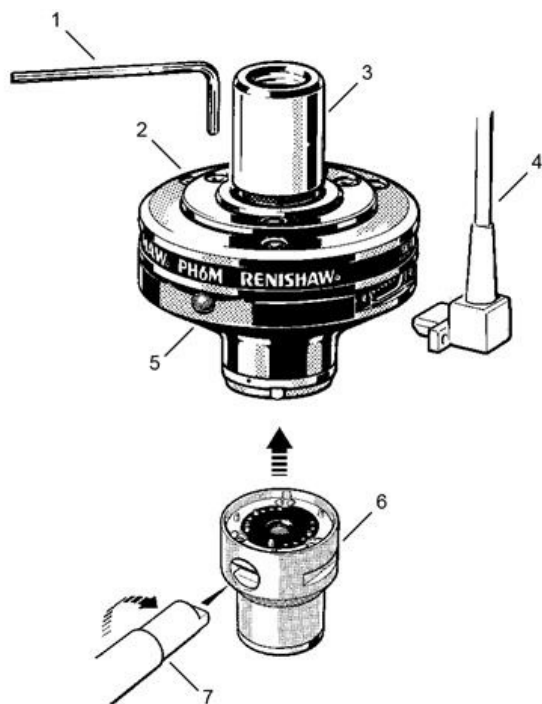

Key	Description
1	Allen key 2.5 A/F
2	M3 × 8 socket head screws (3 off)
3	Shank
4	Multiwire probe cable
5	Probe status LED
6	Autojoint adaptor
7	S10 joint key



PH6M user's guide

www.renishaw.com

# System connection

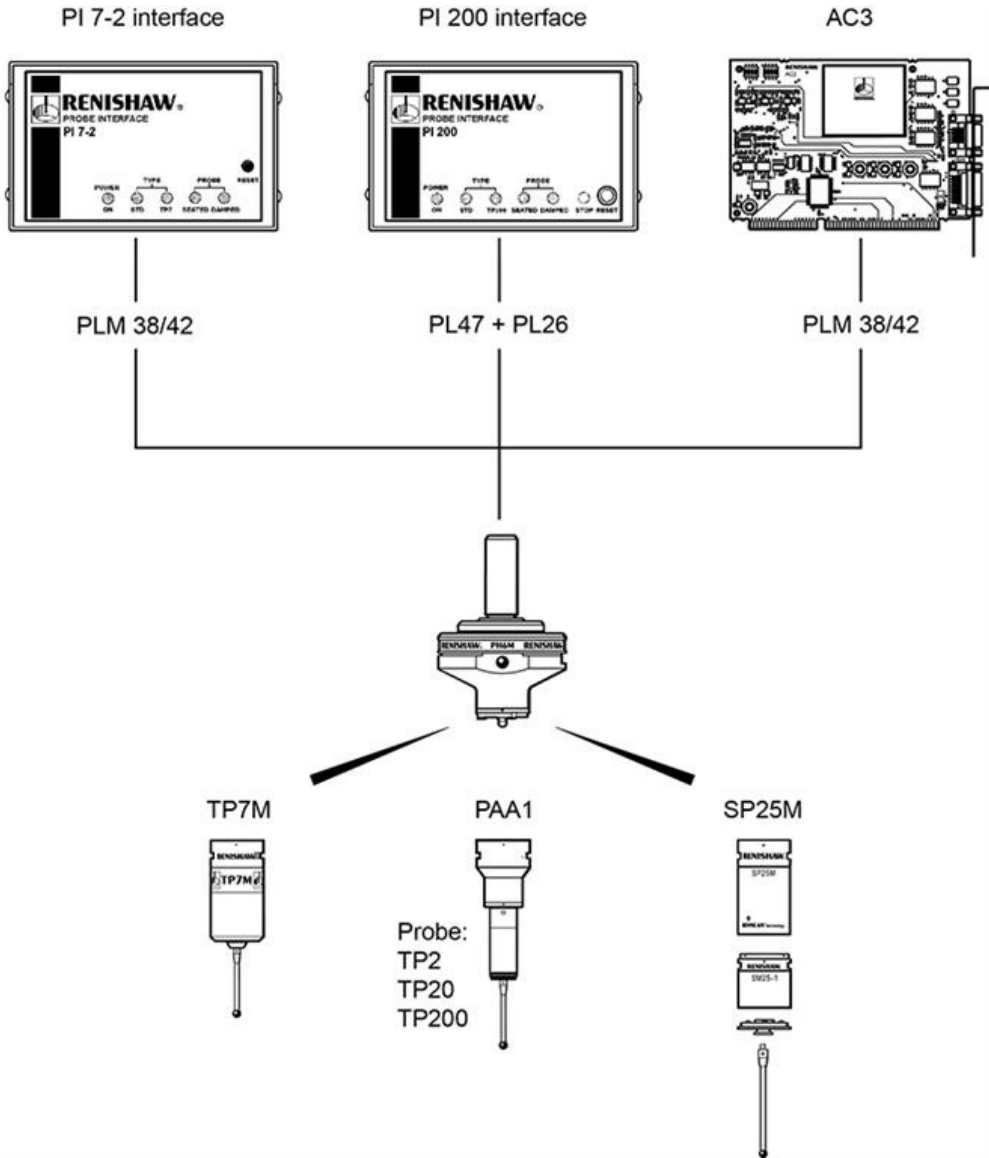

## PH6M user's guide

www.renishaw.com

# Interconnecting cables

There is a choice of standard cables to connect from PH6M to probe interfaces PI 7-2, PI 200, OPI6, the AC2 card for SP600M or the ACR3 card for SP25M.

Connectors shown in brackets are supplied in kit form. The cable is supplied with the micro 'D' connector fitted and the remote end prepared, but unterminated, to facilitate assembly into machine looms.

Termination	Length	Ident	Part number	Notes
(15-way high density 'D')	25 m	PL38	A-1016-7625	Supplied unterminated
(15-way high density 'D')	15 m	PL42	A-1016-7624	Supplied unterminated
Unterminated	12 m	PL56	A-1016-7626	No connector supplied
(15-way high density 'D')	8 m	PL44	A-1016-7627	Supplied unterminated
(15-way high density 'D')	3.7 m	PL46	A-1016-7628	Supplied unterminated
(15-way high density 'D')	1.9 m	PL45	A-1016-7629	Supplied unterminated

Please contact Renishaw for details of cables for PI 200.

## PH6M user's guide

www.renishaw.com

# Specification

<b>Repeatability</b>	1 $\mu\text{m}$ ( $2\sigma$ ) at stylus tip 50 mm (1.97 in) from connector face
<b>Probe compatibility</b>	Direct fitting of SP25M, TP7M, OTP6M, SP600M and TP6A PAA series adaptor/extension required for M8 connector probes TP200, TP20 and TP2
<b>Dimensions</b>	Length: 40 mm (1.57 in) – without shank Diameter: 60 mm (2.36 in)
<b>Weight</b>	160 g (0.36 lb)
<b>Probe mount</b>	Multiwired autojoint
<b>Number of sockets</b>	One
<b>Style of probe joint</b>	Multiwired autojoint
<b>Probe status indication</b>	One LED
<b>Cable connection</b>	15-way micro 'D' connector

PH6M user's guide

www.renishaw.com

# Probe compatibility

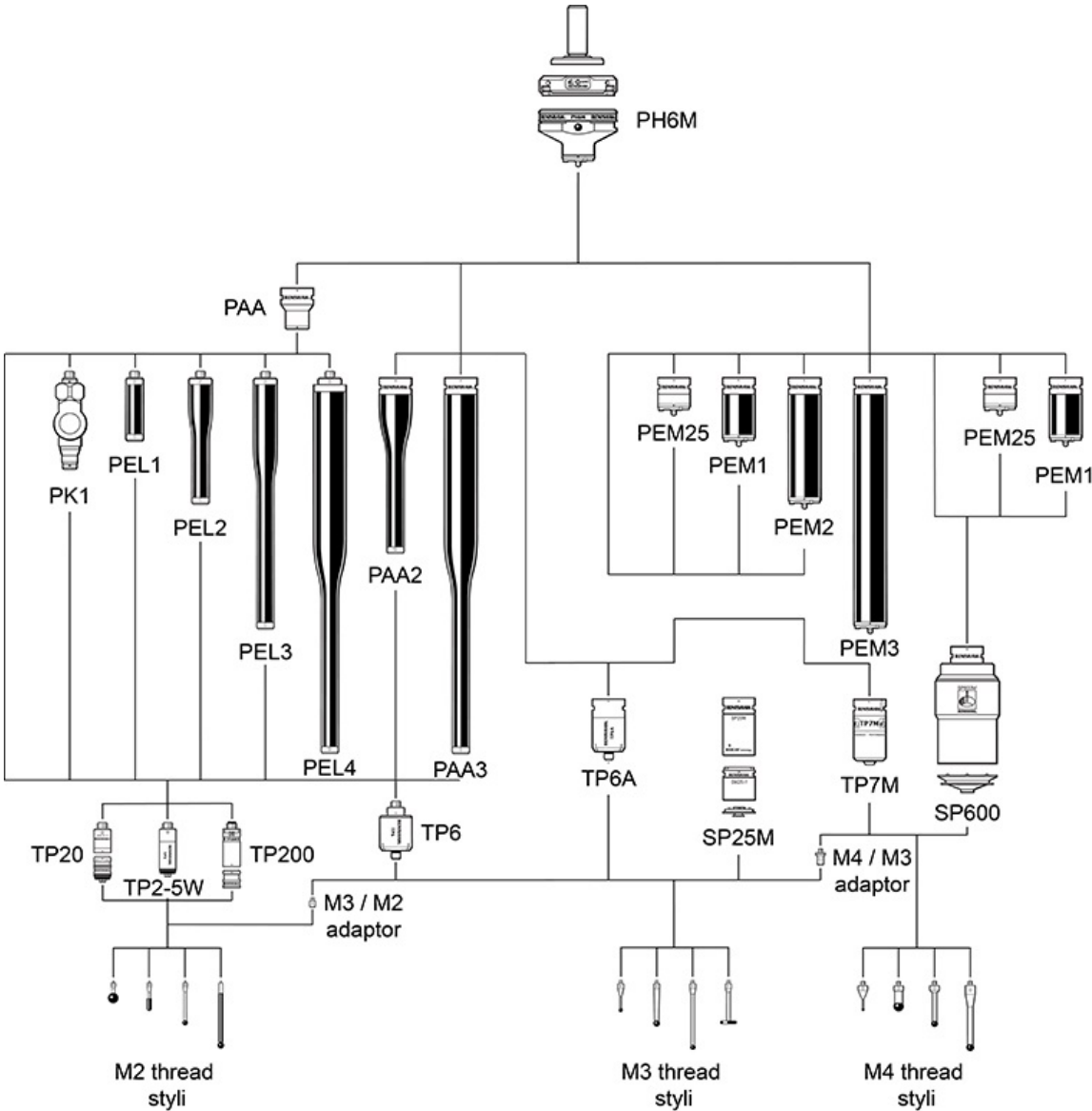

# Accessories and parts lists

## Accessories

Part	Description	Part number
AM1	Adjustment module for precise alignment of the head axes with the CMM or autochange rack	A-1026-0320
S10	Autojoint key	A-1051-0040

## Parts list

Please quote the part number when ordering.

Type	Part number
PH6M + MS1 shank	A-1074-0031
PH6M + MS2 shank	A-1074-0032
PH6M + MS3 shank	A-1074-0033
PH6M + MS9 shank	A-1074-0039
PH6M + MS13 shank	A-1074-0043
PH6M + MS15 shank	A-1074-0045

**Renishaw plc**  
New Mills, Wotton-under-Edge,  
Gloucestershire, GL12 8JR  
United Kingdom

**T** +44 (0)1453 524524  
**F** +44 (0)1453 524901  
[www.renishaw.com/cmmsupport](http://www.renishaw.com/cmmsupport)



**For worldwide contact details,  
please visit our main website at  
[www.renishaw.com/contact](http://www.renishaw.com/contact)**